

User Manual

V1.1

RX33 platform

Parametric controllers for Refrigeration



Introduction

The RX33 platform for refrigeration applications includes a series of MCU-based parametric electronic controllers, with LED display, designed to control stand-alone refrigeration units. these controllers are especially suitable for applications requiring high load switching power, functions and control with direct access from the keypad, high IP ingress protection and compact dimensions.

Main features:

- up to 5 relay outputs on the more complete models: compressor, fan, defrost, AUX1, AUX2;
- front panel installation
- keypad with 4 buttons;
- defrosts can be activated from the keypad, digital input, supervisor/cloud ;
- management of various types of defrost, on one or two evaporators: natural (stopping the compressor), heater, hot gas;
- advanced defrost functions;
- parameter selection simplified by different icons according to the category;
- temperature control with virtual control probe and set point variation at night;
- digital inputs to activate alarms, enable or activate defrosts, door /curtain switch, auxiliary output, on/off , etc.;
- control of one compressor with two steps, or two compressors, including rotation;
- keypad protection: the functions of the individual buttons can be disabled;
- management of the light in the cabinet/cold room and the curtain on the cabinet;
- alarm signal buzzer;
- HACCP functions: temperature monitoring and recording in the event of high temperature alarms during operation and after blackouts;
- RS485 serial network connection to remote supervisor and cloud systems(Modbus RTU);

Dimensions (unit: mm)

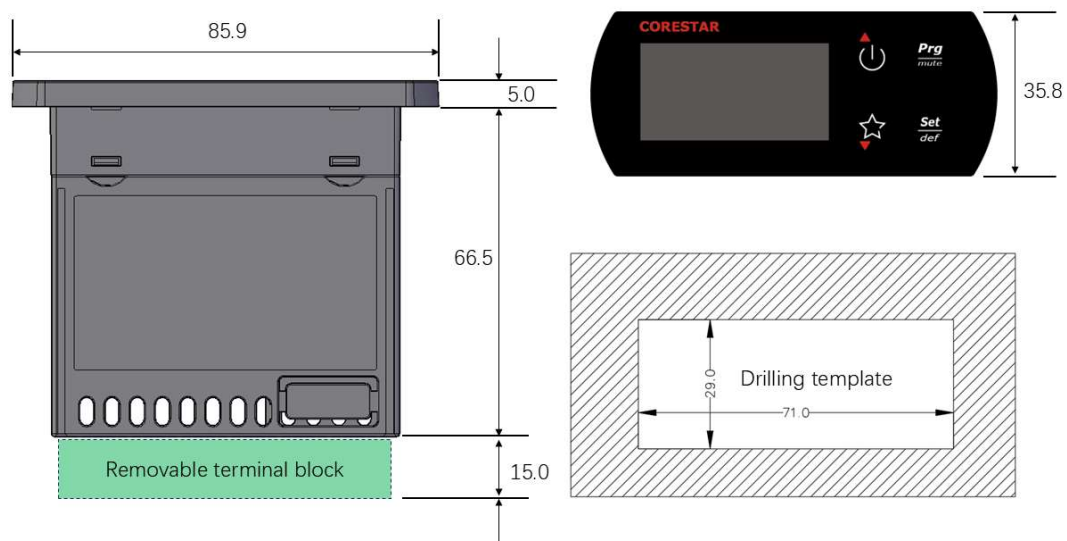

Panel mounting installing/uninstalling

The panel thickness must be between 0.5 and 10.0mm

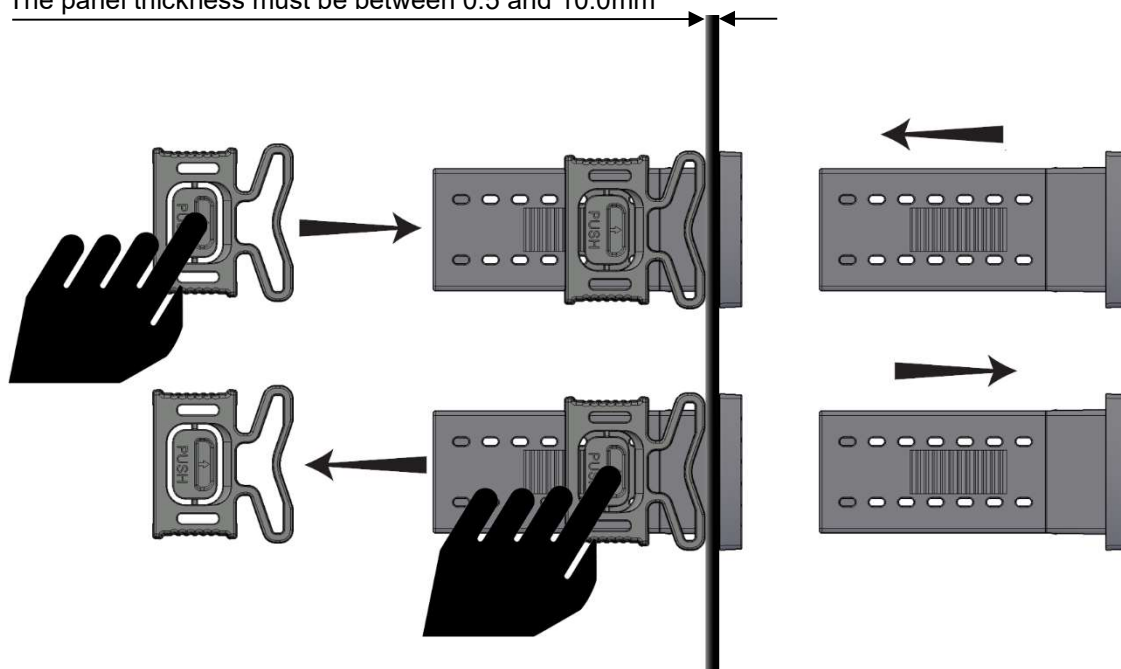

Product coding structure

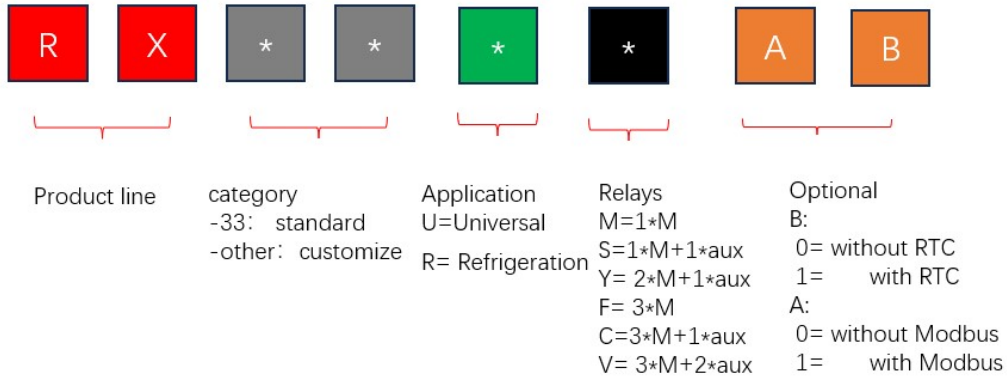

Electrical Specifications

Power supply	100~240Vac, 4VA	
Inputs	S1(Probe 1)	NTC or PT1000
	S2(Probe 2)	NTC or PT1000
	DI1	voltage-free contact, contact resistance < 10 Ω , closing current 6 mA
	S3	NTC or PT1000
	DI2	voltage-free contact, contact resistance < 10 Ω , closing current 6 mA
	S4	NTC or PT1000
Probe type	Normal NTC	10k Ω at 25°C, range from - 50T90°C
	High Temp. NTC	50k Ω at 25°C, range -40T150°C
	PT1000	1000 Ω at 0°C, range from -85T100°C
Relay outputs	R1	250V~, 10(10) A, N.O, SPST
	R2	250V~, 8(4) A, N.O, SPST
	R3,R4	250V~, 8(4) A, N.O/N.C, SPDT
	R4,R5	250V~, 5(3) A, N.O, SPST in model V
*Relay not suitable for fluorescent loads (neon lights, etc.) that use starters (ballasts) with phase shifting capacitors.		
RTC	error at 25°C \pm 10 ppm (\pm 5 min/year), if RTC function available	
Operating temperature	-10T60°C	
Operating humidity	< 90% RH non-condensing	
Front panel IP level	assembly on smooth and indeformable panel with IP65 gasket	
protection against surge	category II	
Communications	Modbus RTU if BMS function available	

Wiring diagrams

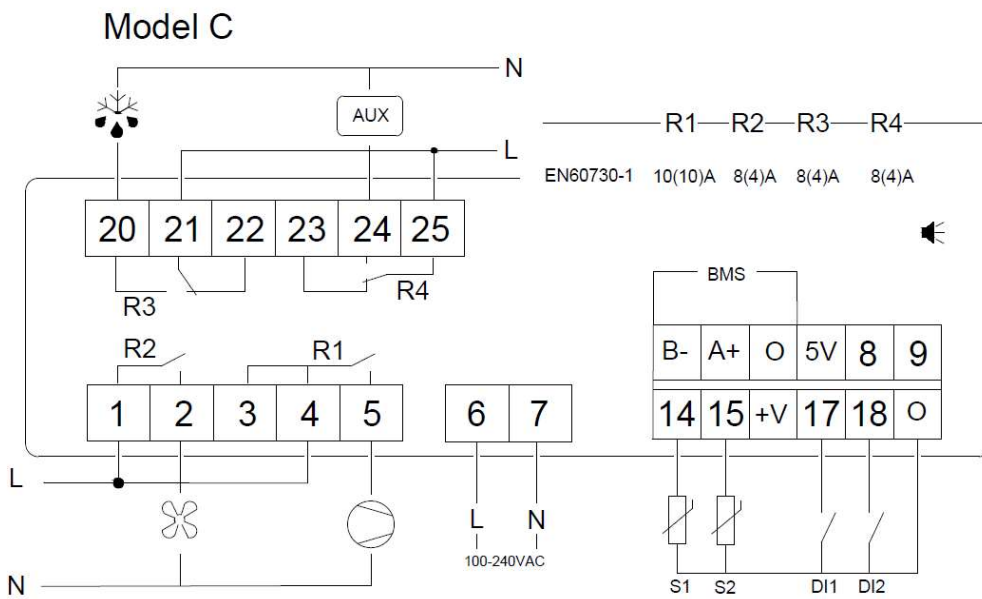
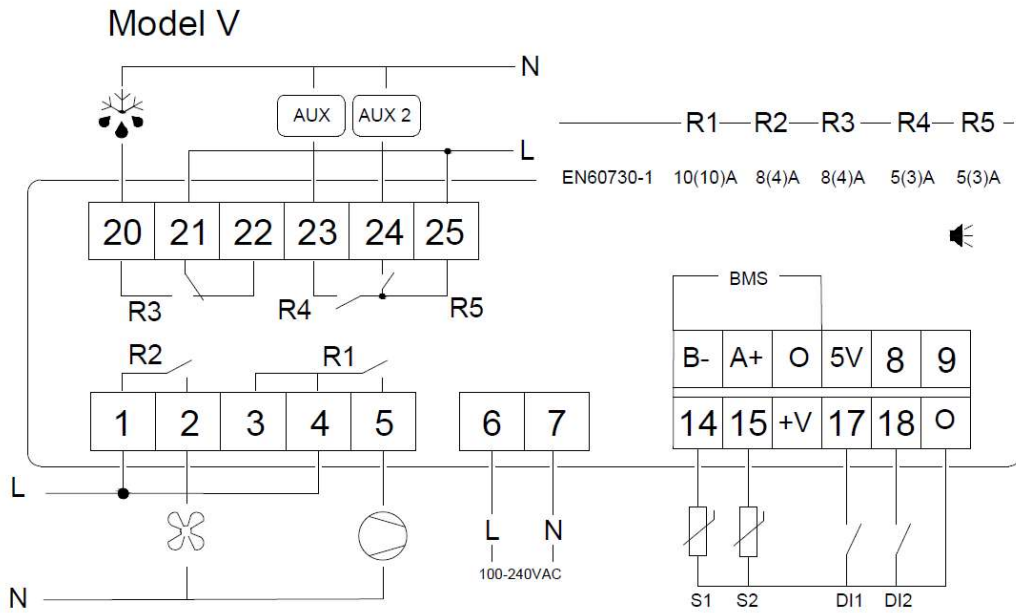

Model Y

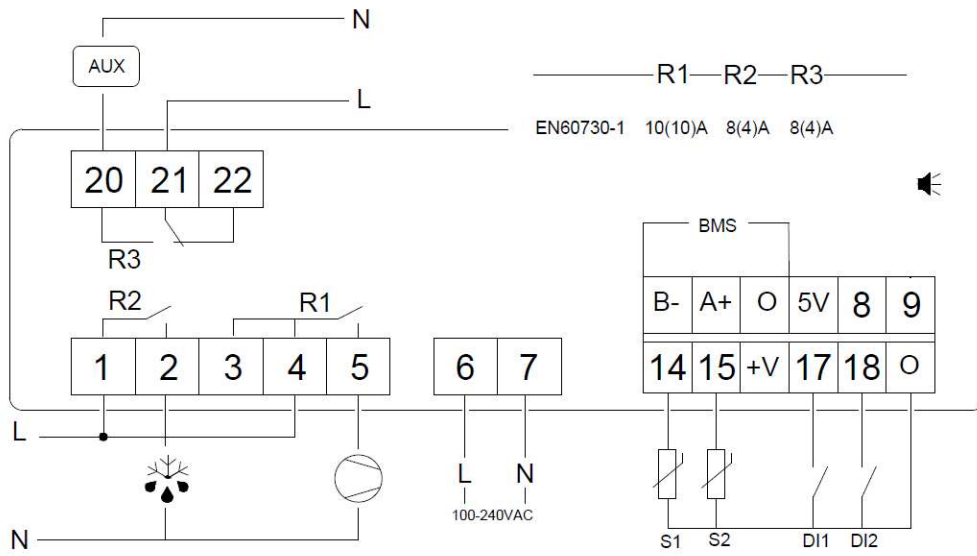

Model F

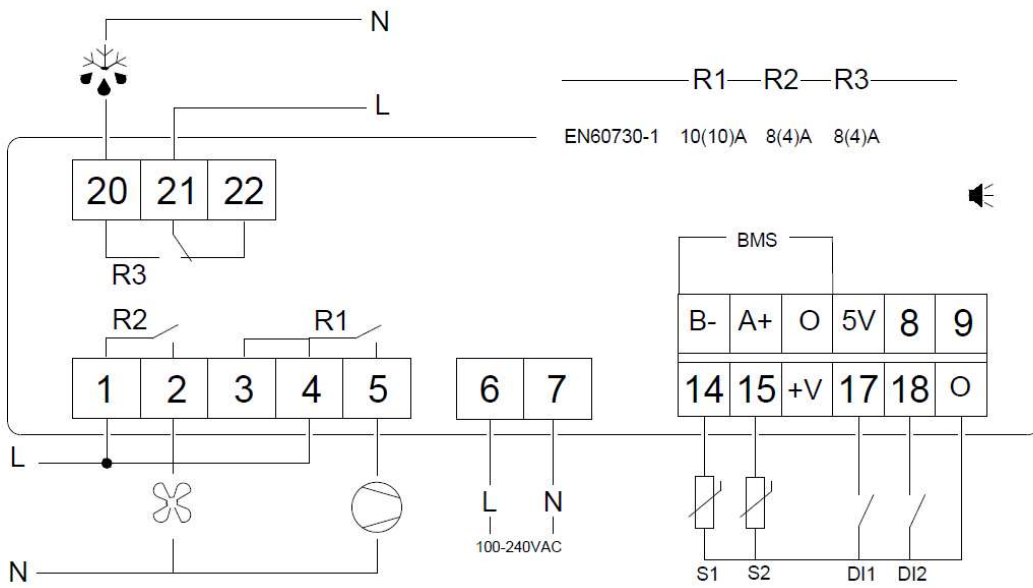

Model S

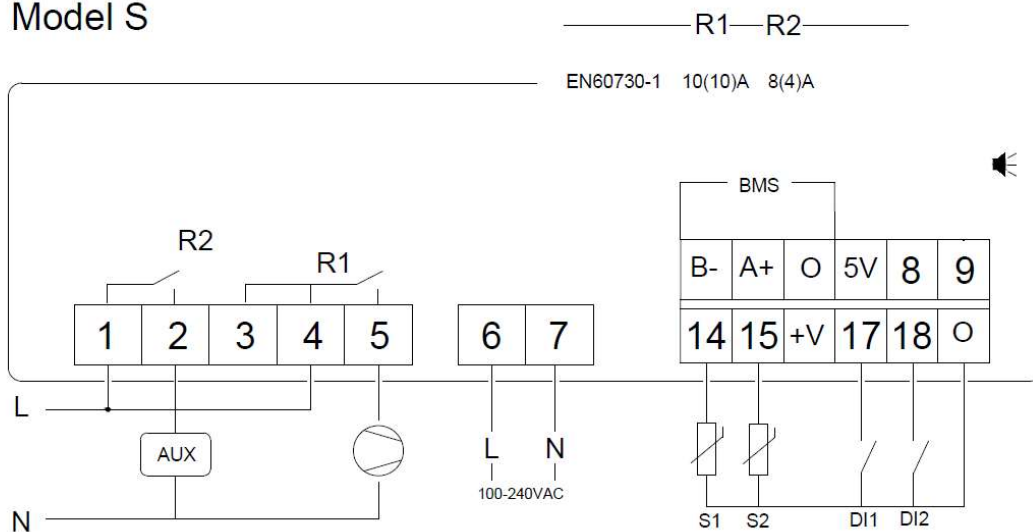

Model M

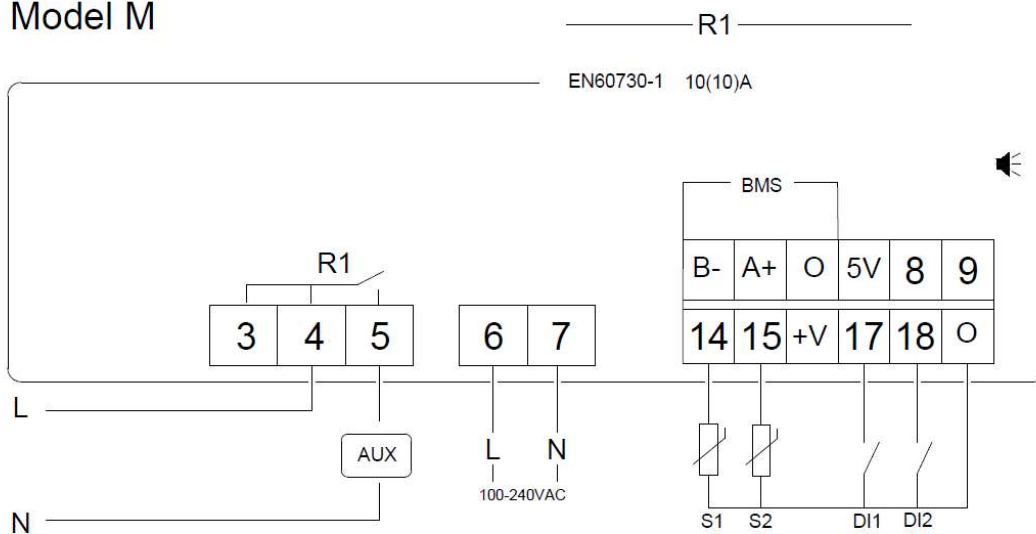

User interface

Interface











Keys

keys	Press and release	Press for at least 5 seconds	Press at Start-up
Prg <i>mute</i>	if there is an active alarm: mutes the audible alarm (buzzer).	accesses the type “F” parameters (frequent)	If pressed more than 3 seconds, activates the procedure for setting the default parameters
Set <i>def</i>	If pressed for more than 1 s, displays and/or lets the user set the set point	starts a manual defrost	
⏻	when setting the parameters, increases the value displayed or scrolls to the next parameter.	switches the controller ON/OFF	
★	when setting the parameters, decreases the value displayed or scrolls to the previous parameter	activates/deactivates the auxiliary output, direct access to the function set with parameter H I	
Prg <i>mute</i> + ⏻		resets any alarms with manual reset	
Prg Set <i>mute</i> + <i>def</i>		access the type “C” parameters (Configuration), default password is 22	
⏻ + ★		activates/deactivates the continuous cycle	
⏻ + Set <i>def</i>		displays the temperature read by the defrost probe	
★ + Set <i>def</i>		displays a submenu used to access the parameters relating to the HACCP alarms	

Display

The user terminal display shows temperature in range -50 to +150°C. The temperature is displayed with resolution to the tenths between - 19.9 and + 19.9 °C. In the event of alarms, the value of the probe is displayed alternating with the codes of the active alarms.

Icons

Icon	Function	ON	OFF	Blink	Start-up
	compressor	ON	OFF	Awaiting	
	fan	ON	OFF	Awaiting	
	defrost	defrosting	-	Awaiting	
<i>AUX</i>	Auxiliary output	aux active	-	Anti-sweat heater function active	
	alarm	Delayed external alarm (before the time 'A7' elapses)	-	Alarms in norm. operation or immediate or delayed alarm from external digital input	
	service			Malfunction (e.g. probe fault).	
	clock	If at least 1 timed defrost event has been set	-	Alarm clock	ON if RTC present
	light	Light ON	-	Anti-sweat heater function active	
	Continuous cycle	Operation activated	-	Flashes when activation is delayed or inhibited by protection times	
HACCP	HACCP	HACCP function enabled	-	HACCP alarm saved	

Parameters List

Catogery	Code	Description	Models	Default	Min	Max	UoM	Type	Modbus Address	R/W
P r o										
C	r 2	Probe measurement stability	MSYFC	4	1	15	-	I	115	R/W
C	r 3	Probe display response(sec) 0=disabled 8=50 1=5 9=60 2=10 10=75 3=15 11=90 4=20 12=105 5=25 13=120 6=30 14=150 7=40 15=180	MSYFC	0	0	15	-	I	116	R/W
C	r 4	Virtual probe composition 0 = control is performed using S1 100 = control is performed using S2	MSYFC	0	0	100	-	I	117	R/W
C	r 5	Select °C or °F 0=°C 1=°F	MSYFC	0	0	1	-	D	40	R/W
C	r 6	Decimal point 0=no 1=yes	MSYFC	0	0	1	-	D	41	R/W
C	r 7	Display on internal terminal 1 = virtual probe 2 = probe 1 3 = probe 2 4 = probe 3 5 = probe 4 6 = probe 5 7 = set point	MSYFC	1	1	7	-	I	118	R/W
C	r P	NTC probe type selection 0 = NTC Normal -50T90°C 1 = NTC HT -40T150°C 2 = PT1000	MSYFC	0	0	2	-	I	120	R/W
C	r R 2	Probe 2 configuration 0 = absent 1 = product (display only) 2 = defrost 3 = condenser 4 = antifreeze	YFC	2	0	4	-	I	121	R/W
			MS	0	0	4	-	I		
C	r R 3	Probe 3 configuration 0 = digital input 1 (DI1) 1 = product (display only) 2 = defrost 3 = condenser 4 = antifreeze	MSYFC	0	0	4	-	I	122	R/W
C	r R 4	Probe 4 configuration 0 = digital input 2 (DI2) 1 = product (display only) 2 = defrost 3 = condenser 4 = antifreeze	MSYFC	0	0	4	-	I	123	R/W
C	r c 1	Probe 1 calibration	MSYFC	0.0	-20	20	-	A	11	R/W
C	r c 2	Probe 2 calibration	MSYFC	0.0	-20	20	-	A	12	R/W
C	r c 3	Probe 3 calibration	MSYFC	0.0	-20	20	-	A	13	R/W
C	r c 4	Probe 4 calibration	MSYFC	0.0	-20	20	-	A	14	R/W
Catogery	Code	Description	Models	Default	Min	Max	UoM	Type	Modbus Address	R/W
C t L										
F	S t	Setpoint	MSYFC	0.0	r1	r2	°C/°F	A	16	R/W
F	r d	regulation differential	SYFC	2.0	0.1	20	°C/°F	A	17	R/W
C	r n	Neutral zone	SYFC	4.0	0	60	°C/°F	A	34	R/W

C	r r	reverse differential	SYFC	2.0	0.1	20	°C/°F	A	35	R/W
C	r i	Minimum Setpoint	MSYFC	-50	-50	r2	°C/°F	A	18	R/W
C	r 2	Maximum Setpoint	MSYFC	60	r1	200	°C/°F	A	19	R/W
C	r 3	Operating mode 0 = Direct with defrost control (cooling) 1 = Direct (cooling) 2 = Reverse (heating)	SYFC	0	0	2	-	I	125	R/W
C	r 4	Automatic variation of night-time setpoint	MSYFC	3.0	-20	20	°C/°F	A	20	R/W
F	r t	Effective interval for monitoring the maximum and minimum temperature.	MSYFC	0	0	999	hour	I	126	R
F	r H	Maximum temperature read	MSYFC	-	-	-	°C/°F	A	21	R
F	r L	Minimum temperature read	MSYFC	-	-	-	°C/°F	A	22	R
Catogery	Code	Description	Models	Default	Min	Max	UoM	Type	Modbus Address	R/W
C N P										
C	c 0	Comp., fan and AUX start delay at power on in neutral zone control	SYFC	0	0	15	min	I	127	R/W
C	c 1	Minimum time between successive compressor starts	SYFC	0	0	15	min	I	128	R/W
C	c 2	Minimum compressor off time	SYFC	0	0	15	min	I	129	R/W
C	c 3	Minimum compressor on time	SYFC	0	0	15	min	I	130	R/W
C	c 4	Compressor running time with duty setting =0: compressor is always OFF when virtual probe error =100: compressor is always ON when virtual probe error	SYFC	0	0	100	min	I	131	R/W
C	c c	Continuous cycle duration	SYFC	0	0	15	hour	I	132	R/W
C	c 5	Low temperature alarm bypass time after continuous cycle	SYFC	2	0	250	hour/min	I	133	R/W
C	c 7	Maximum pump down time =0: pump down disabled	SYC	0	0	900	s	I	134	R/W
C	c 9	Autostart in pump down 0 = Disabled 1 =enable the compressor autostart function in pump down status	SYC	0	0	1	-	D	43	R/W
C	c 10	pump down by Time or by Pressure 0=pressure 1=by time	SYC	0	0	1	-	D	44	R/W
C	c 11	Second compressor delay	SYC	4	0	250	s	I	136	R/W
Catogery	Code	Description	Models	Default	Min	Max	UoM	Type	Modbus Address	R/W
d E F										
C	d 0	Type of defrost 0 = heater by temperature 1 = hot gas by temperature 2 = heater by time (Ed1, Ed2 not shown) 3 = hot gas by time (Ed1, Ed2 not shown) 4 = heater by time with temperature control (Ed1, Ed2 not shown)	SYFC	0	0	4	-	I	137	R/W
F	d 1	Maximum time between defrosts 0 = defrost not performed	SYFC	8	0	250	hour/min	I	138	R/W
F	d t 1	End defrost temperature, evaporator	SYFC	4	-50	200	°C/°F	A	23	R/W
F	d t 2	End defrost temperature, aux evaporator	SYFC	4	-50	200	°C/°F	A	24	R/W
F	d t 3	End defrost temperature, evap. probe 3	SYFC	4	-50	200	°C/°F	A	38	R/W
F	d P 1	Maximum defrost duration, evaporator	SYFC	30	1	250	min/s	I	139	R/W
F	d P 2	Maximum defrost duration, aux evaporator	SYFC	30	1	250	min/s	I	140	R/W

C	d 3	Defrost start delay	SYFC	0	0	250	min	I	141	R/W
C	d 4	Enable defrost at start up	SYFC	0	0	1	-	D	45	R/W
C	d 5	Defrost delay at start-up (if d4=1) or from dl	SYFC	0	0	250	min	I	142	R/W
C	d 6	Display during defrost 0 = Temperature alternating with dEF text 1 = the last temperature before the start of defrost 2 = dEF text only	SYFC	1	0	2	-	I	143	R/W
F	d d	Dripping time	SYFC	2	0	15	min	I	144	R/W
F	d B	Alarm bypass time after defrost and/or door open	SYFC	1	0	250	hour /min	I	145	R/W
C	d B d	Open door alarm delay	SYFC	0	0	250	min	I	239	R/W
C	d 9	Defrost priority over compressor protections	SYFC	0	0	1	-	D	46	R/W
F	d r 1	Defrost probe 1 reading	MSYFC	-	-	-	°C/°F	A	1	R
F	d r 2	Defrost probe 2 reading	MSYFC	-	-	-	°C/°F	A	2	R
C	d C	Time base for defrost 0 = dl in hours, dP 1 and dP2 in minutes 1 = dl in minutes, dP1 and dP2 in seconds	SYFC	0	0	1	-	D	47	R/W
C	d i 0	Compressor running time below d11, after which a defrost request is generated 0 = function disabled	SYFC	0	0	250	hour	I	146	R/W
C	d i 1	Running time defrost temperature threshold	SYFC	1.0	-20	20	°C/°F	A	25	R/W
C	d i 2	Advanced auto-adapting defrosts 0= skip defrost disabled, automatic variation of dl disabled 1= skip defrost disabled, automatic variation of dl enabled 2= skip defrost enabled, automatic variation of dl disabled 3= skip defrost enabled, automatic variation of dl enabled	SYFC	0	0	3	-	I	147	R/W
C	d n	Nominal defrost duration	SYFC	65	1	100	-	I	148	R/W
C	d H	Proportional factor for variation of dl	SYFC	50	0	100	-	I	149	R/W
Catogery	Code	Description	Models	Default	Min	Max	UoM	Type	Modbus Address	R/W
ALN										
C	R 0	Alarm and fan differential	MSYFC	2.0	0.1	20	°C/°F	A	26	R/W
C	R 1	Type of threshold AL and AH 0= relative 1=absolute	MSYFC	0	0	1	-	D	48	R/W
F	R L	Low temperature alarm threshold If A1= 0, AL=0: alarm disabled If A1= 1, AL=-50: alarm disabled	MSYFC	0.0	-50	200	°C/°F	A	27	R/W
F	R H	High temperature alarm threshold If A1= 0, AL=0: alarm disabled If A1= 1, AL=200: alarm disabled	MSYFC	0.0	-50	200	°C/°F	A	28	R/W
F	R d	Low and high temperature alarm delay	MSYFC	120	0	250	min	I	150	R/W
C	R 4	0 = not active 1 = immediate external alarm 2 = delayed external alarm 3 = select probes (Model M) / enable defrost 4 = start defrost 5 = door switch with compressor and evaporator fans off 6 = remote ON/OFF 7 = curtain switch 8 = low pressure switch 9 = door switch with fans off 10 = direct/reverse operation 11 = light sensor 12 = activate aux output 13 = door switch with compressor and fans off and light not managed 14 = door switch with fans off and light not managed	SYFC M	0 3	0	14	-	I I	151	R/W
C	R 5	Digital input 2 configuration see A4	MSYFC	0	0	14	-	I	152	R/W
C	R 6	Stop compressor on external alarm 0 = compressor always off ; 100 = compressor always on	SYFC	0	0	100	min	I	153	R/W

C	R 7	External alarm detection delay 0 = control outputs unchanged	SYFC	0	0	250	min	I	154	R/W															
C	R 8	Enable alarms Ed1 and Ed2 (end defrost by timeout) 0 = alarms disabled	SYFC	0	0	1	-	D	49	R/W															
C	R d o	Light management mode with door switch <table border="1" style="font-size: 8px; width: 100%; border-collapse: collapse;"> <tr> <td>Ado</td> <td>Light Status when opening the door</td> <td>Light actions</td> </tr> <tr> <td></td> <td>OFF</td> <td>ON/door opened;-OFF/door closed)</td> </tr> <tr> <td>0</td> <td>ON</td> <td>ON/door opened;-ON/door closed;-ON/door opened;-OFF/door closed)</td> </tr> <tr> <td></td> <td>OFF</td> <td>ON/door opened;-ON/door closed;-ON/door opened;-OFF/door closed)</td> </tr> <tr> <td>1</td> <td>ON</td> <td>ON/door opened;-OFF/door closed)</td> </tr> </table>	Ado	Light Status when opening the door	Light actions		OFF	ON/door opened;-OFF/door closed)	0	ON	ON/door opened;-ON/door closed;-ON/door opened;-OFF/door closed)		OFF	ON/door opened;-ON/door closed;-ON/door opened;-OFF/door closed)	1	ON	ON/door opened;-OFF/door closed)	MSYFC	0	0	1	-	D	50	R/W
Ado	Light Status when opening the door	Light actions																							
	OFF	ON/door opened;-OFF/door closed)																							
0	ON	ON/door opened;-ON/door closed;-ON/door opened;-OFF/door closed)																							
	OFF	ON/door opened;-ON/door closed;-ON/door opened;-OFF/door closed)																							
1	ON	ON/door opened;-OFF/door closed)																							
C	R c	High condenser temperature alarm	SYFC	70.0	0	200	°C/°F	A	29	R/W															
C	R E	High cond. temp. alarm differential	SYFC	10.0	0.1	20	°C/°F	A	30	R/W															
C	R c d	High condenser temperature alarm delay.	SYFC	0	0	250	min	I	156	R/W															
C	R F	Light sensor switch-off time AF= 0 sensor in the door stop AF> 0 sensor inside the cold room or cabinet	SYFC	0	0	250	s	I	157	R/W															
C	R L F	Antifreeze alarm threshold	MSYFC	-5.0	-50	200	°C/°F	A	36	R/W															
C	R d F	Anti freeze alarm delay	MSYFC	1	0	15	min	I	236	R/W															
Catogery	Code	Description	Models	Default	Min	Max	UoM	Type	Modbus Address	R/W															
F R n																									
C	F 0	Fan Management 0 = always on 1 = activation based on the diff erence between virtual probe andevaporator temperature 2 = activation based on evaporator temperature	FC	0	0	2	-	I	158	R/W															
F	F 1	Fan activation temperature (only if F0 = 1 or 2)	FC	5.0	-50	200	°C/°F	A	31	R/W															
C	F 2	Fan Off with compressor Off 0= fan always ON 1=fan off when compressor off	FC	1	0	1	-	D	51	R/W															
C	F 3	Fans in defrost 0= ON 1=OFF	FC	1	0	1	-	D	52	R/W															
F	F d	Post-dripping time (fans off)	FC	1	0	15	-	I	159	R/W															
C	F 4	Condenser fan stop temperature	MSYFC	40	-50	200	°C/°F	A	32	R/W															
C	F 5	Condenser fan start differential	MSYFC	5.0	0.1	20	°C/°F	A	33	R/W															
Catogery	Code	Description	Models	Default	Min	Max	UoM	Type	Modbus Address	R/W															
C n F																									
C	R d r	Serial address	MSYFC	1	0	207	-	I	160	R/W															
C	H 1	AUX output confi guration 0 = normally energised alarm 1 = normally de-energised alarm 2 = auxiliary 3 = light 4 = auxiliary evaporator defrost 5 = pump down valve 6 = condenser fan 7 = delayed compressor 8 = auxiliary with deactivation when OFF 9 = light with deactivation when OFF 10 = no function 11 = reverse with neutral zone 12 = second compressor step 13 = second compressor step with rotation	MSYC	1	0	13	-	I	161	R/W															
C	H 2	Disable keypad functions	MSYFC	1	0	6	-	I	162	R/W															
C	H 4	Buzzer: 0=enabled 1=disabled	MSYFC	0	0	1	-	D	53	R/W															
C	H 5	Key lock	MSYFC	0	0	255	-	I	164	R/W															
C	H 6	Output switched with scheduler 0 = Light; 1= AUX	MSYFC	0	0	1	-	D	60	R/W															
C	H 9	Set point variation with scheduler 0 = no 1=yes	MSYFC	0	0	1	-	D	61	R/W															

C	<i>b R U</i>	Serial baud rate and parity selection 0= 9600, None 1=19200, None 2=38400, None 3= 9600, Even 4=19200, Even 5=38400, Even 6= 9600, Odd 7=19200, Odd 8=38400, Odd	MSYFC	0	0	8	-	I		R/W
C	<i>H d h</i>	Anti-sweat heater off set 0 = function disabled (°C) 32 = function disabled (°F)	MSYFC	0.0	-50	200	°C/°F	A	37	R/W
Catogery	Code	Description	Models	Default	Min	Max	UoM	Type	Modbus Address	R/W
H c P (if RTC present)										
C	<i>H R n</i>	Number of HA alarms	MSYFC	0	0	15		I	167	R
C	<i>H R 1</i> <i>H R 2</i>	HA HACCP alarms activated (press Set)	MSYFC	-	-	-		I		R
	<i>Y - -</i>	Alarm 1 to 3 - Year	-	0	0	99	years	I	170	R
	<i>M - -</i>	Alarm 1 to 3 - Month	-	0	1	12	month	I	171	R
	<i>d - -</i>	Alarm 1 to 3 - Day of the month	-	0	1	7	day	I	172	R
	<i>h - -</i>	Alarm 1 to 3 - Hour	-	0	0	23	hour	I	173	R
	<i>n - -</i>	Alarm 1 to 3 - Minute	-	0	0	59	min	I	174	R
	<i>t - -</i>	Alarm 1 to 3 - Duration	-	0	0	99	hour	I	175	R
C	<i>H F n</i>	Number of HF alarms	MSYFC	0	0	15		I	176...181	R
C	<i>H F 1</i> <i>H F 2</i>	HF HACCP alarms activated (press Set)	MSYFC	-	-	-		I	-	R
	<i>Y - -</i>	Alarm 1 to 3 - Year	-	0	0	99	years	I	188	R
	<i>M - -</i>	Alarm 1 to 3 - Month	-	0	1	12	month	I	189	R
	<i>d - -</i>	Alarm 1 to 3 - Day of the month	-	0	1	7	day	I	190	R
	<i>h - -</i>	Alarm 1 to 3 - Hour	-	0	0	23	hour	I	191	R
	<i>n - -</i>	Alarm 1 to 3 - Minute	-	0	0	59	min	I	192	R
	<i>t - -</i>	Alarm 1 to 3 - Duration	-	0	0	99	hour	I	193	R
C	<i>H t d</i>	HACCP alarm delay 0 = Monitoring disabled	MSYFC	0	0	250	min	I	169	R/W
Catogery	Code	Description	Models	Default	Min	Max	UoM	Type	Modbus Address	R/W
r t c (if RTC present)										
C	<i>td1..8</i>	Defrost 1 to 8 (press Set)	SYFC	-	-	-	-	-	-	
	<i>d - -</i>	Defrost 1 to 8 - day 0 = event disabled 1 to 7 = Monday to Sunday 8 = from Monday to Friday 9 = from Monday to Saturday 10 = Saturday and Sunday 11 = every day		0	0	11		I	206/209.../227	R/W

	h _ _	Defrost 1 to 8 - hour		0	0	23			207/210.../228	R/W
	n _ _	Defrost 1 to 8 - minute		0	0	59			208/211.../229	R/W
C	t o n	Light/aux on time	SYFC	-	-	-	-	-	-	
	d _ _	Day		0	0	11			230	R/W
	h _ _	Hour		0	0	23			231	R/W
	n _ _	Minute		0	0	59			232	R/W
C	t o F	Light/aux off time	SYFC	-	-	-	-	-	-	
	d _ _	Day		0	0	11			233	R/W
	h _ _	Hour		0	0	23			234	R/W
	n _ _	Minute		0	0	59			235	R/W
C	t c	Date/time (press Set)	MSYFC	-	-	-	-	-	-	
	y _ _	Date/time: year		24	0	99			101	R/W
	m _ _	Date/time: month		6	1	12			102	R/W
	d _ _	Date/time: day of the month		1	1	31			103	R/W
	w _ _	Day of the week		1	1	7			104	R/W
	h _ _	Date/time: hour		0	0	23			105	R/W
	n _ _	Date/time: minute		0	0	59			106	R/W